

TeraRanger Neo ES

User manual

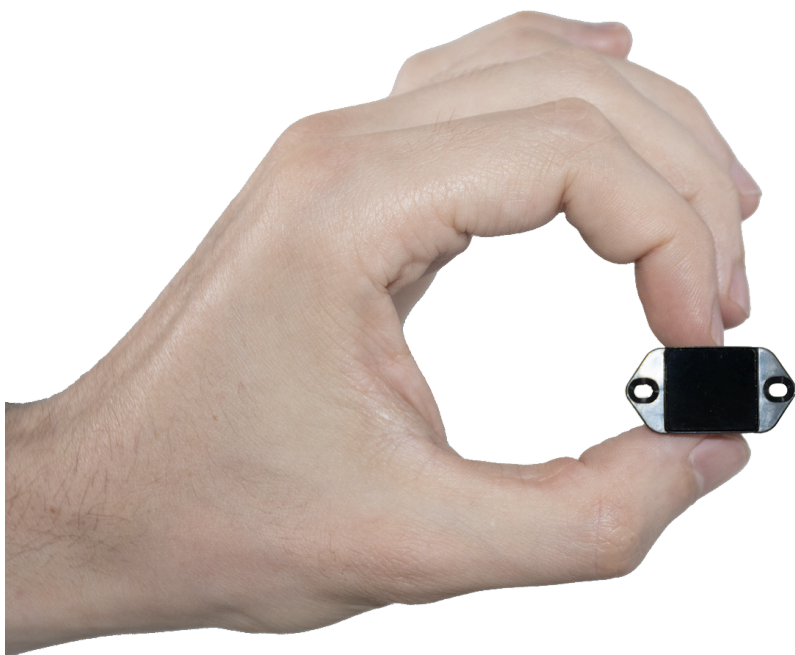

Document version v1.1

Many thanks for buying our TeraRanger Neo ES sensor.

TeraRanger Neo ES is the next generation of TeraRanger range finders. By using indirect ToF, TeraRanger Neo ES will provide highly accurate distance measurements in a compact, lightweight form, with exceptionally low power consumption. The front panel is designed to enable integrations that can achieve IP65 protection.

This guide provides you with all the information needed to use and fully integrate our sensor in your system.

If you have any questions or remarks regarding the product, please contact your commercial representative or our technical support at terabee.com/support/.

Table of contents

1. About the TeraRanger Neo ES	4
1.1. Inside the package	4
1.2. Technical specifications	4
1.2. Symbols explanation	5
2. Sensor use	6
2.1. LED Indication	6
2.2. Connecting the TeraRanger Neo ES to a host computer	7
2.2.1. Windows OS	7
2.2.2. Example HTerm output	9
3. UART Communication	10
3.1. UART pinout	10
3.2. Electrical characteristics	11
3.3. Configuration commands	11
3.3.1. Command composition	11
3.3.2. List of commands	13
3.4. Sensor payload	13
3.5. Status codes	14
3.6. Distance error cases	15
3.7. Sample Python script to read data	16
3.8. In case of device failure	18
4. Sealed front panel and integration	19

1. About the TeraRanger Neo ES

1.1. Inside the package

You will receive the following items when purchasing the TeraRanger Neo ES:

- TeraRanger Neo ES **x1**
- Molex cable Open-End **x1**
- Nylon screw (Flathead) M2 x 0.4 mm x 12 mm **x2**
- Nylon nut (Hex) M2 x 0.4 mm **x2**
- Rubber joint x 1 mm **x1**

1.2. Technical specifications

Product code	TR-NEO-ES
Performance	
Detection principle	Infrared Indirect Time-of-Flight
Range*	0.2 - 30 m
Update rate	25 readings per second
Output resolution	1 mm
Accuracy	Approx. 1-2% of measured value
Field of View	Approx. 2.2°
Electronics	
Supply voltage	5V DC +/-5%
Supply current (min-max)	50 mA average (250 mW on 5 V rail)
Communication	
Interface	LP UART, +3.3 V level (+/-5%), 9600,8,N,1
Connector	Molex - CONN HEADER SMD 4POS 1.25MM
Mechanical data	
Dimensions	Height 30.5 mm; Width 15.5 mm; Depth 28.2 mm; Screw holes 2 mm \varnothing
Weight	Approx. 6 g
Operating conditions	0°C to 60°C (measured inside the sensor)
Ingress protection	Sealed front panel for potential IP65 integration
Eye safety	Yes
Conformity	
Reference standard	CE, RoHS

Table 1 - Technical specifications

*Specifications are derived from tests in controlled conditions. Bright sunlight, target surface reflectivity and other variables will affect sensor performance. The combination of very bright sunshine and low reflectivity targets (such as grass) can reduce maximum range. For additional information, please find the following [test results report](#).

1.2. Symbols explanation

The following symbols are used within the document:



This symbol indicates specific recommendations in order to run the sensor in the intended way.

2. Sensor use

2.1. LED Indication

Two LED indicators are present on the PCB, and are visible through the back side. The LED indicators can be used to troubleshoot the sensor.

LED designator	Description	Action
Green LED flashes "8 times" on startup then switches off	Normal startup behavior.	No action
Green LED flashes at regular time intervals of around 5 seconds	Green LED flashing indicates normal sensor operation.	No action
Red LED blinking rapidly at ~100ms intervals.	Sensor has detected a fault in the device and has stopped functioning	Check the cable connector and restart.

Table 2 - LED indicators

2.2. Connecting the TeraRanger Neo ES to a host computer

2.2.1. Windows OS

Hardware needed:



(1) TeraRanger Neo ES,
(2) Molex cable Open-End

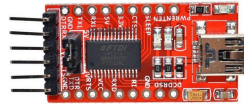

(3) FTDI UART to USB
(not included)



(4) computer
(not included)

On Windows it is possible to use any terminal emulation software for data display. Terabee often works with and suggests using HTerm software. Please follow the provided link to download the software file (<http://www.der-hammer.info/terminal/>), and select the version **0.8.5** of the software.

Next, extract the downloaded zip file to the selected folder, open it and double click on the "HTerm.exe" document. Connect the TeraRanger Neo ES to a computer and select the corresponding USB port (click "R" button to refresh the port list). Please configure the software with the following parameters:

Baud rate : 9600 bit/s
Data bits : 8
Parity bit : None
Stop bit : 1

See [Figure 1](#) below for visual instructions.

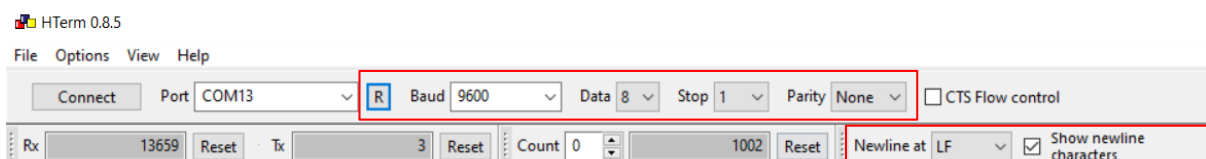

Figure 1 - HTerm parameters for TeraRanger Neo ES

Once the USB port is selected and the parameters correctly set, click on the **“Connect”** button. The distance data will now appear in the **“Received data”** box (see [Figure 2](#)).

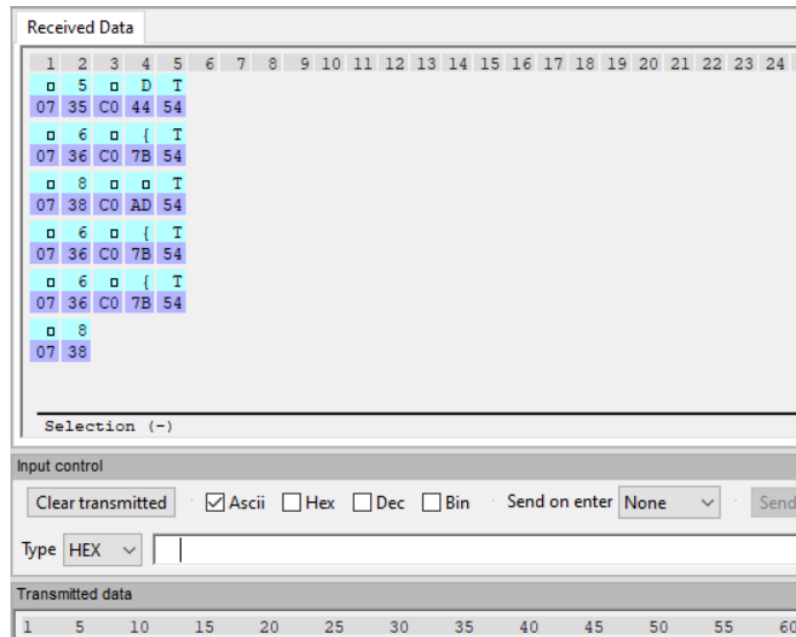

Figure 2 - Data stream on HTerm software

To communicate with the terminal emulation software, a command in hexadecimal needs to be sent using the **“Type”** field. Make sure the **“Hex”** checkbox is selected (checked) and the **“Type”** field has **“HEX”** as an option selected. [Figure 3](#) shows an example of the command which enables low power mode.

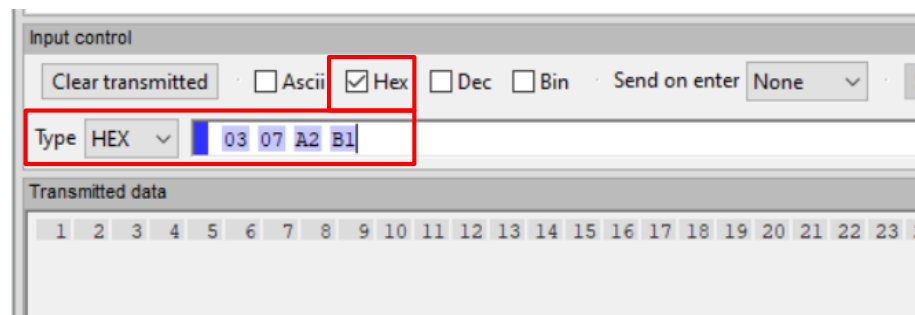

Figure 3 - Example of command which enables low power mode



The data output format is in Hexadecimal. There is no other output format available. See [Figure 4](#) to easily understand how to read the distance values in decimal format.

2.2.2. Example HTerm output

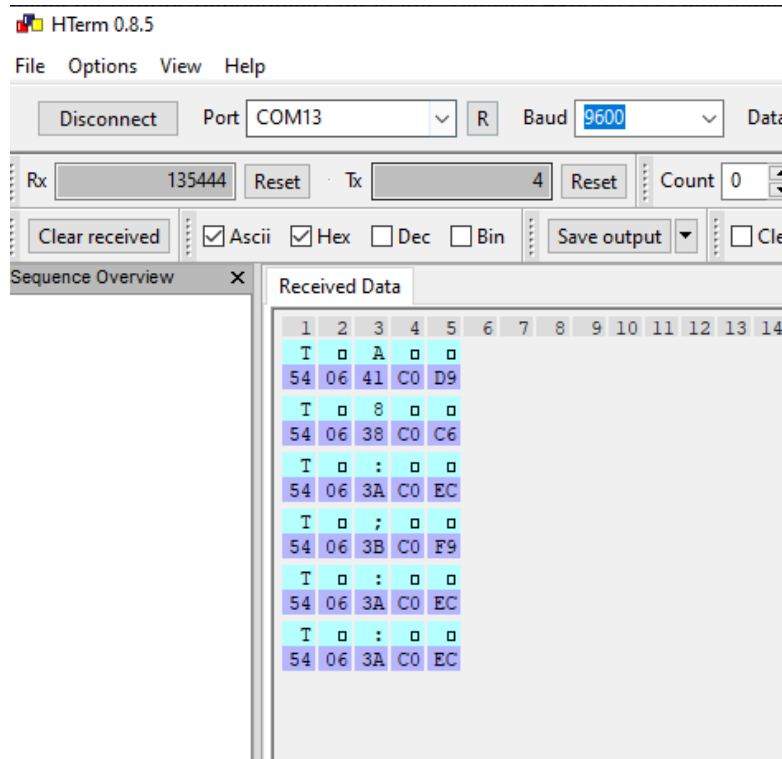

Figure 4 - Example of HTerm output

If we look at the frame "T 06 41 C0 D9" as an example we have:

The real distance measured is: 1601 millimeters.

FRAME HEADER: T

MSB DISTANCE: 0x06

LSB DISTANCE: 0x41

STATUS CODE: 0xC0₍₁₆₎ = 1100 0000₍₂₎ => QF = 6₍₁₀₎ (value is between 90% & 100%)

CRC: 0xD9

Refer to the section [Sensor payload](#) which describes the payload in detail.

3. UART Communication

The TeraRanger Neo ES is controlled through a UART interface.

3.1. UART pinout

The UART interface uses a single 4 pin Molex connector for interfacing to the host system. The mating connector is a Molex - CONN HEADER SMD 4POS 1.25MM. Please consider the mechanical stability of the mated connectors and avoid any kind of excess force on the connector (during installation and once integrated).

Pin	Designator	Description
1	5 V	+5 V supply input
2	Tx	UART transmits output. 3.3 V logic
3	Rx	UART receives input. 3.3 V logic
4	GND	Power supply and interface ground

Table 3 - Pinout and description

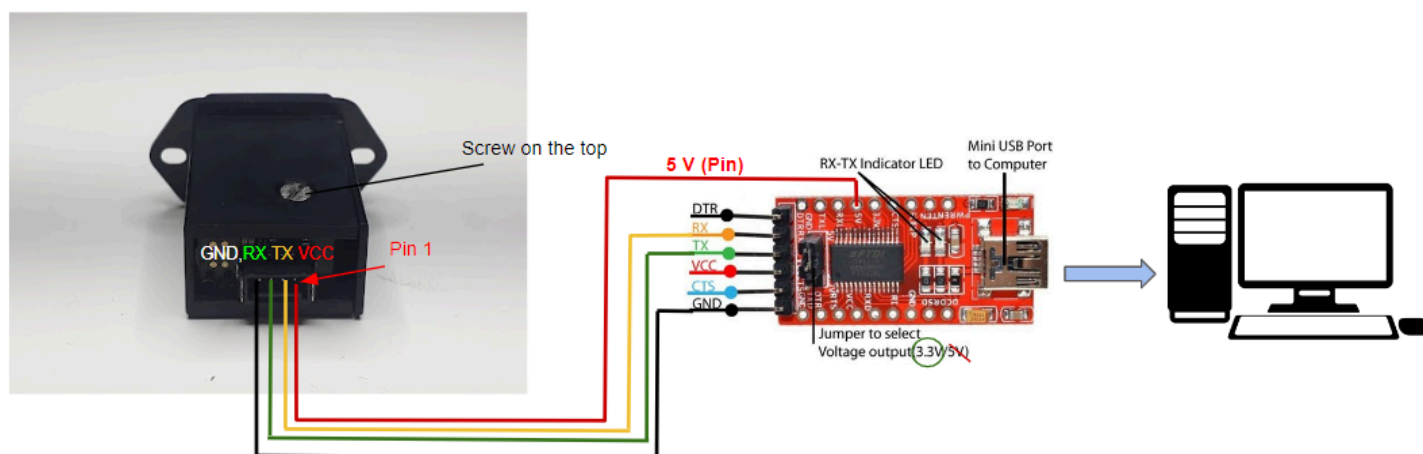

Figure 5 - Wiring connection Neo ES sensor to a computer

3.2. Electrical characteristics

Parameter	Minimum	Maximum	Average
Power supply			
Voltage input (V)	4.5 V	5.5 V	5 V
Current consumption (mA)	45 mA	55 mA	50 mA
Interface logic levels (referenced to +3V3)			
LOW	-	1	-
HIGH	2.3	-	-

Table 4 - TeraRanger Neo ES power consumption

Use with a power supply limited to 1 A maximum

3.3. Configuration commands

3.3.1. Command composition

The Query (Q):

The query frame contains length (in bytes is the sum of the length, command and data), command code, N bytes of the data and a CRC-8 checksum of the entire frame in the last byte, for the commands that only read data, the query will not include any data bytes, but the response will.

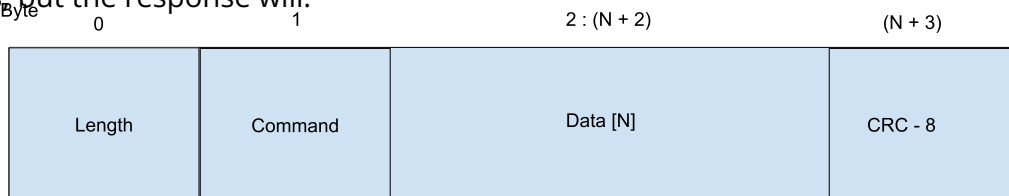

The Response (R):

The response contains:

- The length of the reply message without the CRC-8 byte
- The command code (same code that was received)
- Data (only if the query was to read data from the device) otherwise ACK or NACK
- CRC-8 calculated for the entire message without the actual CRC byte (i.e. from length byte to the last data byte, both included)

Length

Represents the sum of the length, command and the data transmitted.

Contents of the Data Field

The Data Field contains the data corresponding to the Command to be executed. The data field cannot be empty."

1. An ACKnowledged message contains length, current command, Data and CRC.
2. Non-ACKnowledged message contains length, current command, "command NACK/CRC mismatch /unknown command" and CRC.

Contents of the CRC-8 Field

The error checking field contains an 8 bit value which is the result of a Cyclic Redundancy Check (CRC) calculation performed on the message contents. The CRC field is appended to the message as the last field in the message.

Error handling case:

The failure case : **a mismatch is detected between the length byte and the actual data sent or an unknown command or command not executed.**

The reply will be a 4 bytes frame:

Length	Command	Command Error 0x00- No Error/No data 0xFF- NACK 0xCC - Crc mismatch 0xEE - Unknown command	CRC-8



Each command message frame must be transmitted in a continuous stream, i.e. not byte by byte



It is advised to maintain a time interval of a few microseconds between two messages for proper command registration

3.3.2. List of commands

Description	Query in HEX	Response in HEX
ENABLE LOW POWER Sensor goes into low power mode	0x03 0x07 0xA2 0xB1	0x03 0x07 0xXX CRC Where XX can be an ACK or NACK
LOW POWER WAKEUP Sensor wakes up from low power mode	0x03 0x08 0xA3 0x75	0x03 0x08 0xXX CRC Where XX can be an ACK or NACK
DEVICE RESET Performs a soft reset	0x02 0x05 0x31	The device performs a software reset. Normal startup logic follows (200ms delay until data starts streaming).

Table 5 - Valid sensor commands

Please refer to [Connecting the TeraRanger Neo ES to a Host Computer](#) for instructions on how to send commands to the sensor using a host computer and the HTerm emulation software

3.4. Sensor payload

This mode provides users with measured distances displayed in the form of binary messages using 5 bytes: **TXXSCRC8**.

The Payload will contain 3 bytes of data (2 for **distance in mm**, 1 status byte), and 2 metadata bytes (header and checksum).

Status byte: Two bits to indicate overtemperature (>50°C) and critical temperature (>60°C) , three bits to indicate the status of distance measurement and three bits to indicate the quality factor of the distance measurement.

The checksum byte is calculated out of the first 4 bytes of the message (header byte, distance reading bytes, and status code byte)

- Header (1 byte)** : T (84 decimal / 0x54 hex)
- Distance reading in mm (2 bytes)** : XX (MSB, LSB)
- Status Code Byte (1 Byte)** : S (One byte to indicate code status of distance measurement. See the Status Codes section below).
- Checksum (1 byte)** : CRC8

Byte 1	Byte 2	Byte 3	Byte 4	Byte 5
"T" FRAME HEADER	MSB DISTANCE	LSB DISTANCE	STATUS CODE	CRC-8

3.5. Status codes

Certain status codes will be detected and reported by the firmware using the 4th byte of the payload. Each bit in the byte represents a status flag as described below.

High nibble			Low nibble				
BIT 0	BIT 1	BIT 2	BIT 3	BIT 4	BIT 5	BIT 6	BIT 7
QUALITY_FACTOR	QUALITY_FACTOR	QUALITY_FACTOR	DISTANCE_STATUS	DISTANCE_STATUS	DISTANCE_STATUS	CRITICAL_TEMP	OVER_TEMP
						Critical temperature (>60°C)	Overtemperature (>50°C)

Quality factor bits - (Signal quality level):

The sensor gives out a quality factor for every distance measurement with a value from 0 - 100 and this is converted to 3 bits from value to 0 to 6 where 0 is very poor and 6 is best quality.

Quality Factor	Value
0 - 25	0
25 - 50	1
50 - 60	2
60 - 70	3
70 - 80	4
80 - 90	5
90 - 100	6

DISTANCE_STATUS:

Gives the status of the distance measurement using values between 0 and 4, where:

- 0 => no error
- 1 => min range
- 2 => out of range
- 3 => ambient light too high
- 4 => invalid reading

OVER_TEMP: If this bit is set (1), the device is above 50°C

CRITICAL_TEMP: If this bit is set (1), the device is above 60°C



The sensor will output T01CRC (first distance byte set to zero and the second to one) as an error message if the sensor is unable to measure a distance. Please refer to [Distance error cases](#) for more details about error cases.

3.6. Distance error cases

Error cases output	BINARY
Detection below sensors minimum range	0X0000
Detection beyond sensors maximum range	0XFFFF
Invalid reading: <ul style="list-style-type: none">- out of range- ambient light too high- invalid reading	0x0001



Note that in some cases, the sensor might not distinguish properly between errors i.e. if below minimum range but then a reading comes with very poor quality, the error will change to "Invalid reading"

3.7. Sample Python script to read data



This sample code is a goodwill gesture to our customers. It is made to help our customers speed up their applications. This sample code is not made to be copy and paste as each customer has a different setup.

```
#!/usr/bin/env python3
#-----
--
# Created By   : TERABEE
# Created Date: 01-03-2022
# version     ='1.0'
#
#-----

import serial, time
import serial.tools.list_ports

quality_factor_mask = 224
status_mask = 28

print('Searching Ports...')
ports = serial.tools.list_ports.comports(include_links = False)
for port in ports :
    print('Find port '+ port.device)

ser = serial.Serial(port.device)
if ser.isOpen():
    ser.close()

ser = serial.Serial(port.device,9600,timeout=1)
ser.flushInput()
ser.flushOutput()
print('Successfully Connected to ' + ser.name)

while True:
    try:
        data = ser.read()
        if data == b'\x54':
```



```

raw = ser.read(3)
dist = int((list(raw)[0] << 8) | list(raw)[1])
full_status = list(raw)[2]

status = full_status & status_mask
qf      = full_status & quality_factor_mask

if(status == 0x00):
    status_response = "Reading status: No error"
elif(status == 0x04):
    status_response = "Reading status: Minimum Range"
elif(status == 0x08):
    status_response = "Reading status: Out of Range"
elif(status == 0x0C):
    status_response = "Reading status: ambient lightning high"
elif(status == 0x10):
    status_response = "Reading status: invalid reading"

if(qf == 0xC0):
    qf_response = "QF is 90-100%"
elif(qf == 0xA0):
    qf_response = "QF is 80-90%"
elif(qf == 0x80):
    qf_response = "QF is 70-80%"
elif(qf == 0x60):
    qf_response = "QF is 60-70%"
elif(qf == 0x40):
    qf_response = "QF is 50-60%"
elif(qf == 0x20):
    qf_response = "QF is 25-50%"
elif(qf == 0x00):
    qf_response = "QF is 0-25%"

print('ToF Distance in [mm]:',dist,qf_response,status_response)
ser.flushInput()

except:
    print("Keyboard Interrupt")

```

3.8. In case of device failure

In case of device failure, perform the following troubleshooting list:

If RED LED is blinking:

- Check the wiring in your setup
 - Ensure correct [PIN 1 position](#)
 - RX from the TeraRanger Neo ES goes to TX of FTDI
 - TX from the TeraRanger Neo ES goes to RX of FTDI
- Sensor needs to be powered with 5V and not with 3.3 V
- Ensure that your power supply can provide at least 250mW at 5V

If this sequence does not work, contact your commercial representative or our technical support team at terabee.com/support/ and indicate the following information:

- Describe in details your setup
- Pictures of your wiring in details
- Video of the LED sequence
- Detailed description of your FTDI

4. Sealed front panel and integration

The front panel of the TeraRanger Neo (the black screen of the sensor) is sealed for a high degree of ingress protection. It may be possible to achieve IP65 protection with the proper integration. The rubber gasket can help achieve a secure integration.



Front panel in detail



Rubber gasket

It is the customer's responsibility to test and validate the final IP rating of the sensor integration.



We suggest tightening the screws (included) gently with a maximum torque of 0.1Nm . The use of a washer is recommended (not included).

The name TERABEE® and the  ® are registered trademarks in the following countries: China, European Union, France, South Korea, Switzerland, Taiwan, United Kingdom and United States.

Terabee reserves the right to make changes, corrections, modifications or improvements to this document, and the products and services described herein at any time, without notice.